

## scheda tecnica - data sheet

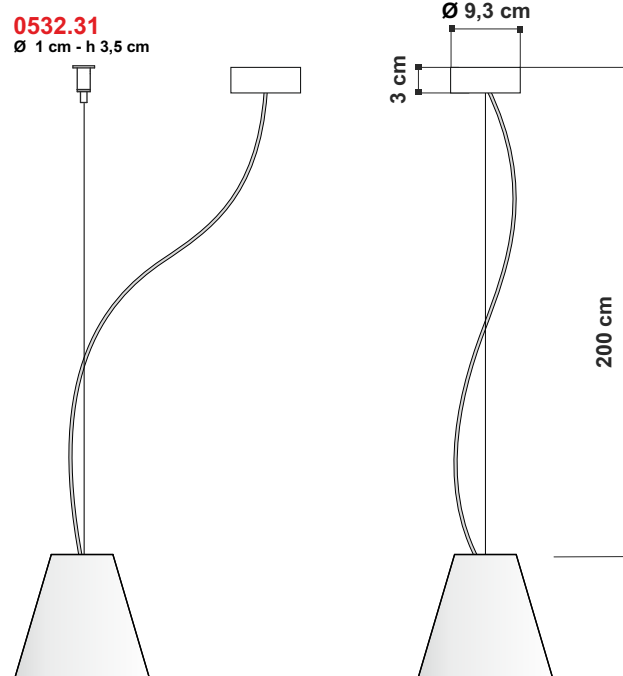

modello: model:	<b>LIOLÀ</b>
codice: code:	<b>1104</b>
design:	<b>ABS Studio</b>
anno -year:	<b>2007</b>
tipologia: typology:	<b>lampada a sospensione suspension lamp</b>
materiali: materials:	<b>struttura in metallo e ABS diffusore in vetro soffiato satinato metal and ABS structure, satin blown glass diffuser</b>
luce: light:	<b>diffusa diffuse</b>
sorgente luminosa: light sources:	<b>3,5W G9 LED</b>
grado IP - IP grade:	<b>20</b>
peso netto - net weight:	<b>0,70 Kg</b>
finiture: finishes:	<b>.57 vetro bianco .57 white glass</b>
optional:	<b>0532.31 elemento per decentramento displacement component</b>
marcatatura: marking:	<b>CE</b>
simboli costruttivi: symbols:	<b>F</b>

Dimensioni del diffusore in vetro - Glass diffuser dimensions

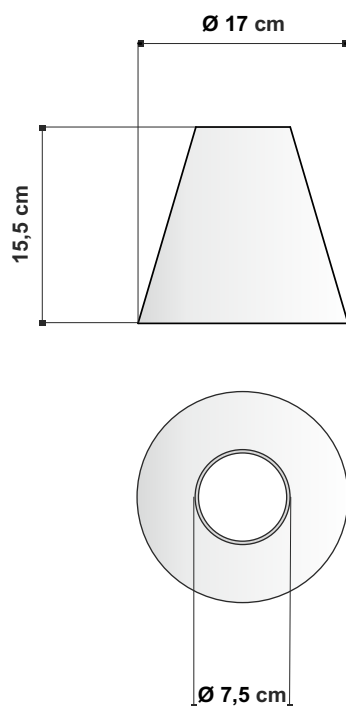

EGOLUCE s.r.l, via I.Newton 12 - 20016 Pero - Milano  
 telefono +39 02 3395861 - fax. +39 02 3535112  
 e-mail: info@egoluce.com - http://www.egoluce.com

## scheda tecnica - data sheet



modello: model:	<b>LIOLÀ</b>
codice: code:	<b>1106</b>
design:	ABS Studio
anno -year:	1996
tipologia: typology:	lampada a sospensione suspension lamp
materiali: materials:	struttura in metallo e ABS diffusore in vetro soffiato satinato metal and ABS structure, satin blown glass diffuser
luce: light:	diffusa diffuse
sorgente luminosa: light sources:	12W E27 LED 15W E27 LED
grado IP - IP grade:	20
peso netto - net weight:	2,5 Kg
finiture: finishes:	.57 vetro bianco .57 white glass
optional:	<b>0532.31</b> elemento per decentramento displacement component
marcatatura: marking:	<b>CE</b>
simboli costruttivi: symbols:	<b>F</b>

Dimensioni del diffusore in vetro - Glass diffuser dimensions

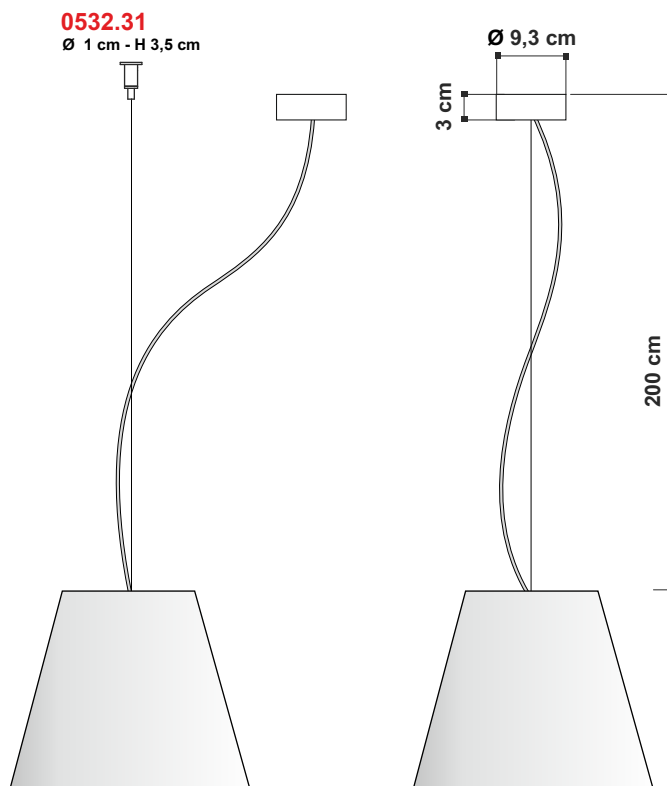
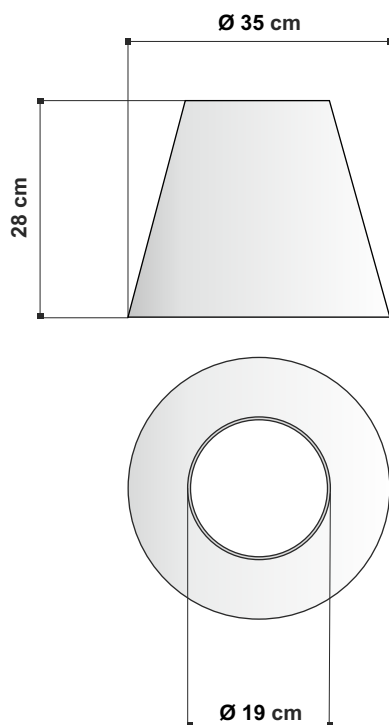

EGOLUCE s.r.l., via I. Newton 12 - 20016 Pero - Milano  
 telefono +39 02 3395861 - fax. +39 02 3535112  
 e-mail: info@egoluce.com - http://www.egoluce.com

## scheda tecnica - data sheet



modello: model:	<b>LIOLÀ</b>
codice: code:	<b>1107</b>
design:	<b>ABS Studio</b>
anno -year:	<b>2007</b>
tipologia: typology:	<b>lampada a sospensione suspension lamp</b>
materiali: materials:	<b>struttura in metallo e ABS diffusore in vetro soffiato satinato metal and ABS structure, satin blown glass diffuser</b>
luce: light:	<b>diffusa diffuse</b>
sorgente luminosa: light sources:	<b>12W E27 LED 15W E27 LED</b>
grado IP - IP grade:	<b>20</b>
peso netto - net weight:	<b>1,2 Kg</b>
finiture: finishes:	<b>.57 vetro bianco .57 white glass</b>
optional:	<b>0532.31 elemento per decentramento displacement component</b>
marcatatura: marking:	<b>CE</b>
simboli costruttivi: symbols:	<b>F</b>

Dimensioni del diffusore in vetro - Glass diffuser dimensions

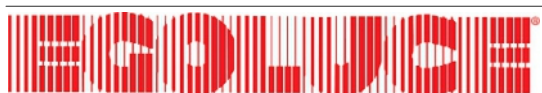
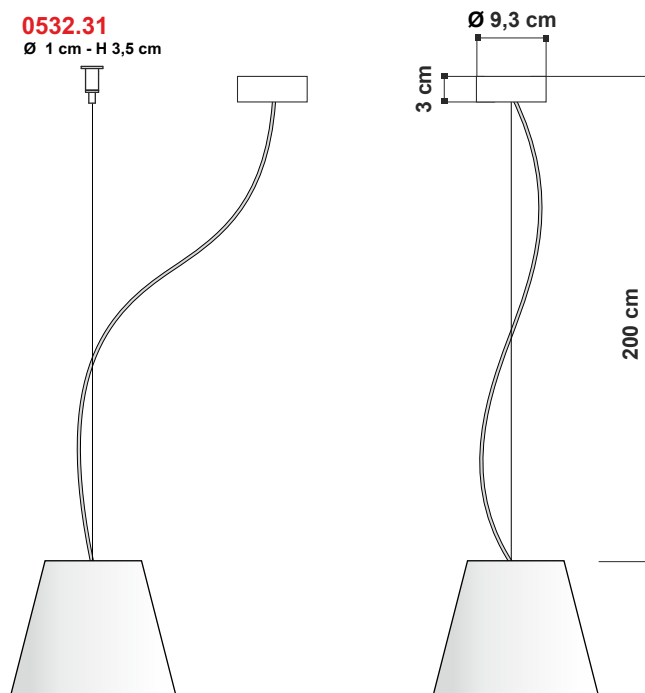
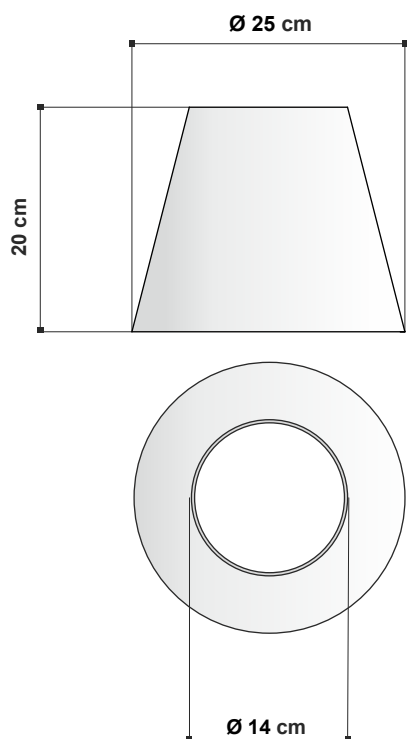

EGOLUCE s.r.l., via I. Newton 12 - 20016 Pero - Milano  
 telefono +39 02 3395861 - fax. +39 02 3535112  
 e-mail: info@egoluce.com - http://www.egoluce.com

## scheda tecnica - data sheet



modello: model:	<b>LIOLÀ</b>
codice: code:	<b>1108</b>
design:	<b>ABS Studio</b>
anno -year:	<b>2007</b>
tipologia: typology:	<b>lampada a sospensione suspension lamp</b>
materiali: materials:	<b>struttura in metallo e ABS diffusore in vetro soffiato satinato metal and ABS structure, satin blown glass diffuser</b>
luce: light:	<b>diffusa diffuse</b>
sorgente luminosa: light sources:	<b>12W E27 LED 15W E27 LED</b>
grado IP - IP grade:	<b>20</b>
peso netto - net weight:	<b>4,20 Kg</b>
finiture: finishes:	<b>.57 vetro bianco .57 white glass</b>
optional:	<b>0532.31 elemento per decentramento displacement component</b>
marcatore: marking:	<b>CE</b>
simboli costruttivi: symbols:	<b>F</b>

Dimensioni del diffusore in vetro - Glass diffuser dimensions

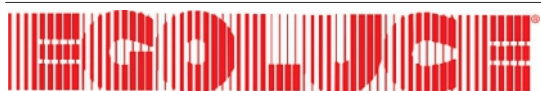
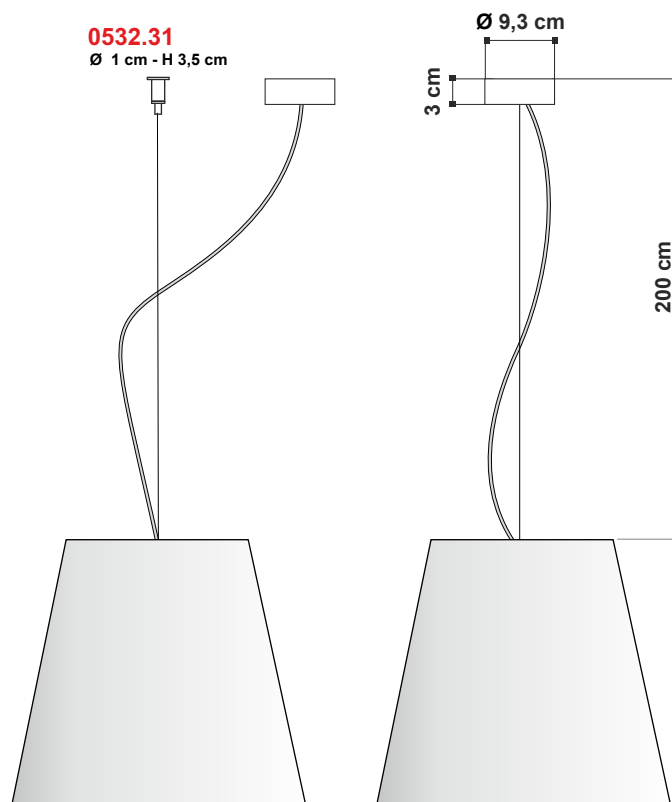
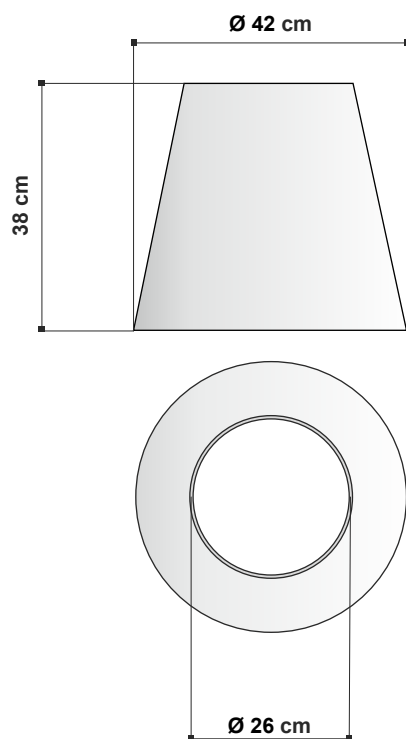

EGOLUCE s.r.l., via I.Newton 12 - 20016 Pero - Milano  
 telefono +39 02 3395861 - fax. +39 02 3535112  
 e-mail: info@egoluce.com - http://www.egoluce.com